

**Waves**

1 The diagram represents a segment of a string along which a transverse wave is travelling.

(i) What is the amplitude of the wave?

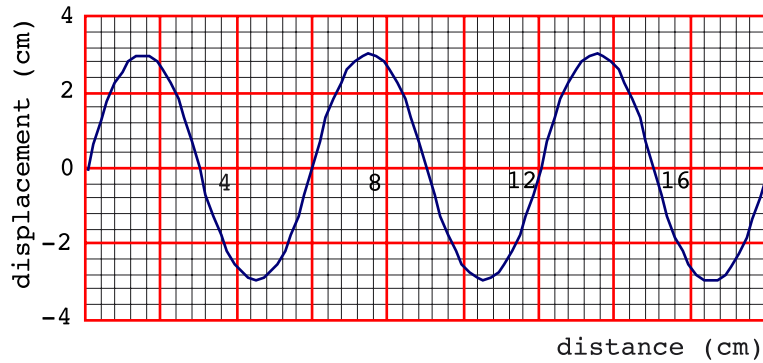

\_\_\_\_\_ [1]

(ii) What is the wavelength of the wave?

\_\_\_\_\_ [1]

(iii) how many cycles are shown in the diagram?

\_\_\_\_\_ [1]

2 The diagram shows a segment of a transverse wave drawn full scale. The frequency of this wave is 2 Hz.

Measure its amplitude and wavelength

\_\_\_\_\_  
 \_\_\_\_\_  
 \_\_\_\_\_ [2]

A2 WAVES

3 The diagrams below show a stretched slinky spring drawn to a scale 1 cm = 5 cm. Diagram A shows a section of the slinky before a wave reaches it. Diagram B shows the slinky at an instant as a wave travels through it.

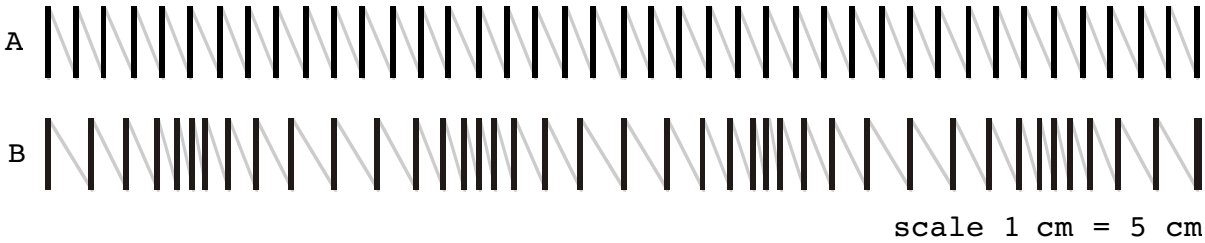

(a) What kind of wave is travelling through the slinky?

\_\_\_\_\_ [1]

(b) On diagram B mark two successive compressions and two successive rarefactions. [1]

(c) Use a ruler and the scale of the diagram to determine the wavelength of this wave.

\_\_\_\_\_ [1]

(d) Find and mark a coil in diagram B that has moved furthest from its equilibrium position in diagram A, and hence determine the amplitude of the wave.

\_\_\_\_\_  
\_\_\_\_\_ [2]

- 4 The speed,  $c$ , of a transverse wave along a string or wire under tension is given by  $c = \sqrt{\frac{T}{\mu}}$ , where  $T$  is the Tension in Newtons and  $\mu$  is the mass per unit length in kg/m.

(a) Show that this equation is homogeneous.

---



---



---

[2]

- (b) The diagram shows a wire of length 2 metres kept in tension by hanging a weight from one end. The mass per unit length for this wire is 5 g/m. If the weight that keeps the wire in tension is 0.5 Newtons. A vibrator is used to produce standing waves in the wire.

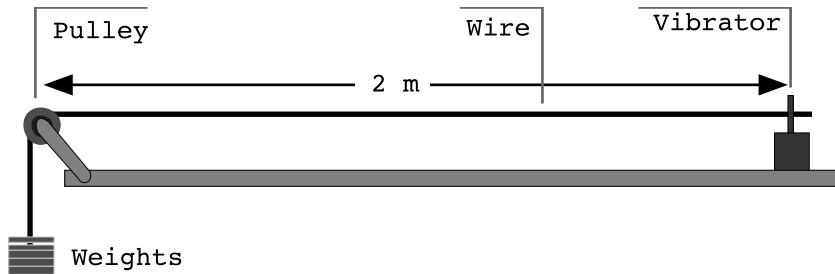

- (i) calculate the speed of the transverse wave travelling along the wire when it is oscillating.

---



---



---

[2]

- (ii) Does the speed of the wave depend on the frequency at which the vibrator oscillates the wire? Explain your answer.

---



---



---

[2]

- (iii) Calculate the wavelength of the fundamental.

---



---

[2]

- (iv) What is the lowest frequency for standing waves in this set up?

---



---



---

[2]

(c) Draw diagrams to show the first four harmonics for standing waves. In each case calculate the wavelength and frequency of the standing wave. Show all working.

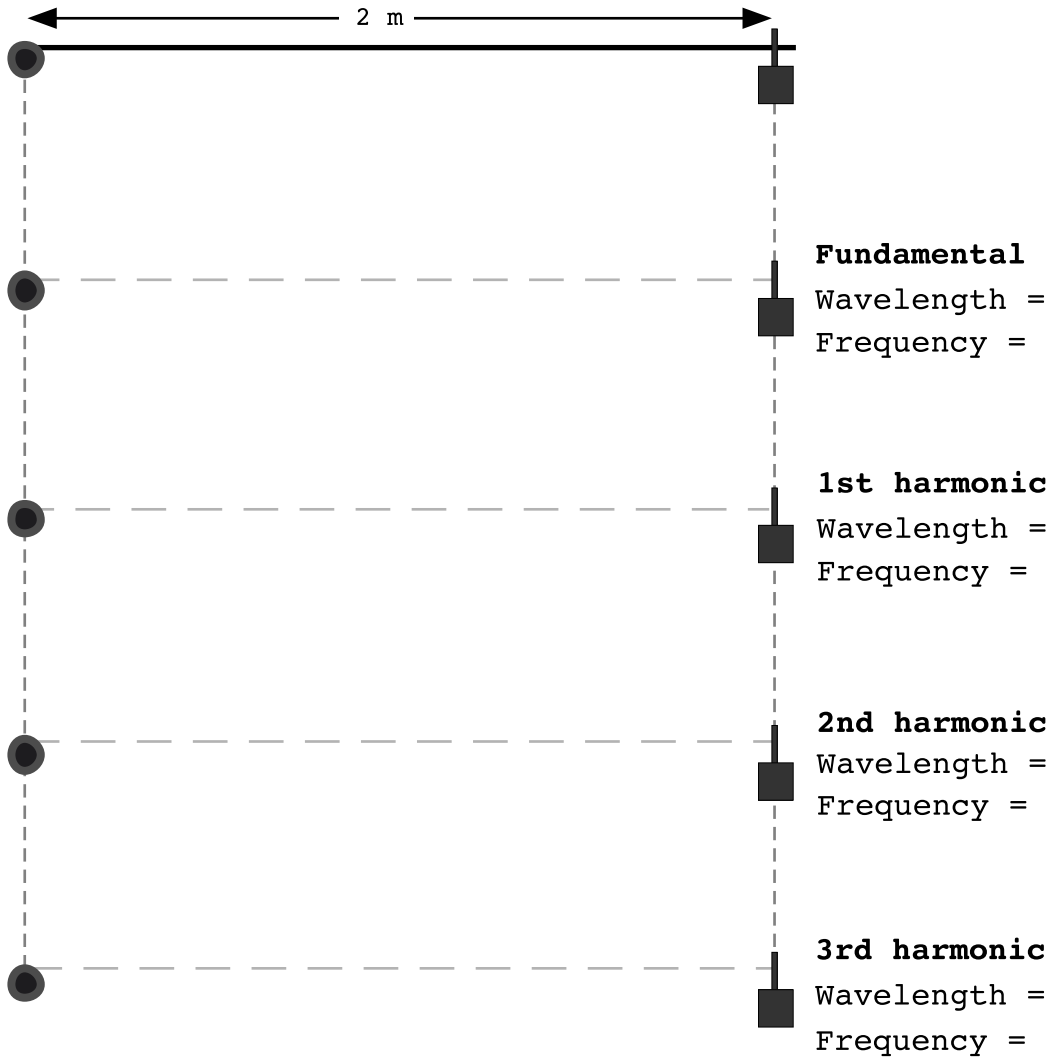

A2 WAVES

5 The diagrams on the right show snapshots of successive positions of a segment of a string at intervals of  $\frac{1}{8}$ <sup>th</sup> of the period of the wave.

(a) Mark the nodes on one of the diagrams, and explain why these points are nodes.

---



---



---

(b) Mark the positions of the antinodes, and explain why these points are antinodes.

(c) Use the scale on the diagrams to determine the amplitude and wavelength of the standing wave.

---



---



---

(d) How many cycles are displayed in these diagrams?

---

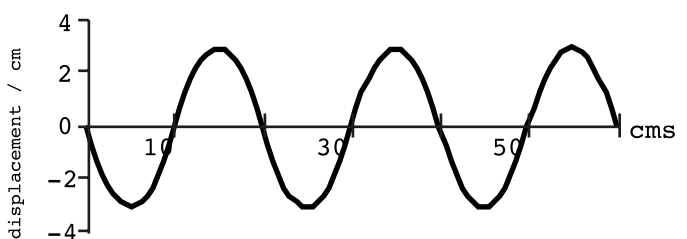
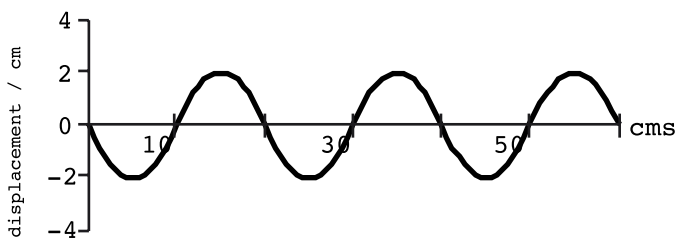
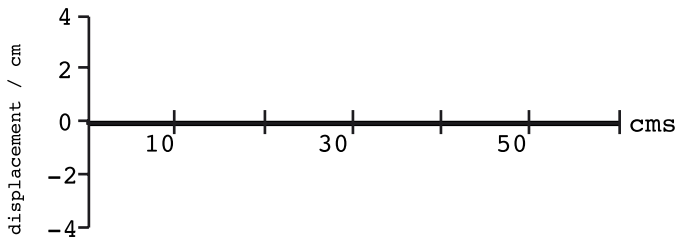
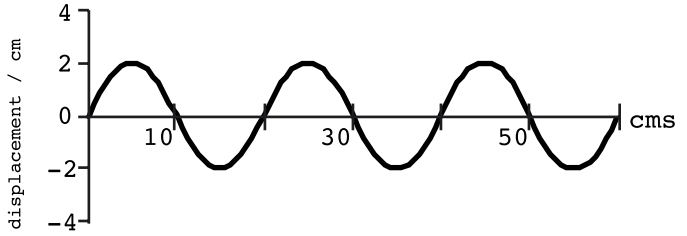
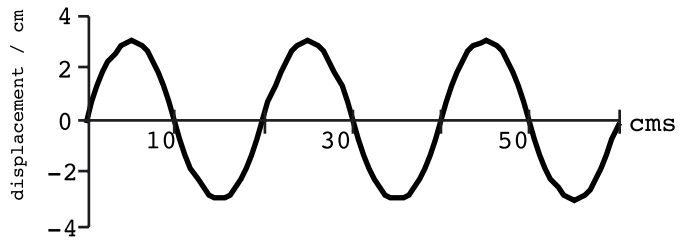

(e) If the time interval between successive diagrams is 0.1 seconds, calculate the frequency of the standing wave, and hence its speed.

---



---



---



---



---

[3]

- 6 The diagram shows a pulse, P, travelling up a heavy rope. The rope is firmly attached to a ceiling at A. Given that the speed of a transverse wave through a string is given by  $c = \sqrt{T/\mu}$ , will the speed of the pulse change as it moves up the rope, and if so does the speed increase or decrease. Explain your answer as fully as you can.

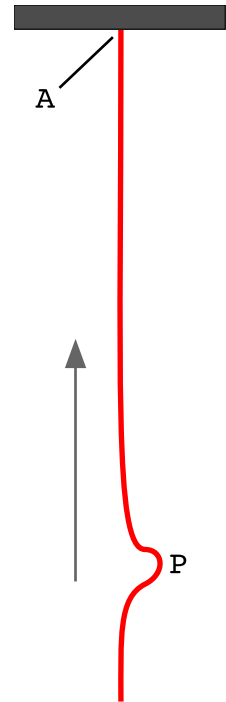

---

---

---

---

---

---

[2]

# Circuits

Name & Set

- 1 The battery in the circuit below has an e.m.f. of 5.4 V and drives a current of 0.30 A through the lamp.

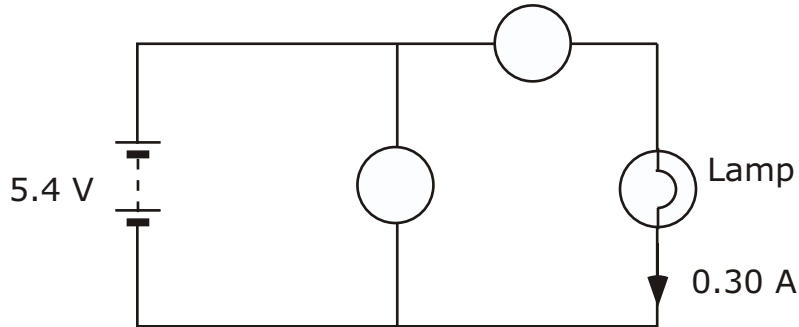

- (a) On the circuit above, label the voltmeter **V** and the ammeter **A**. [1]  
 (b) The voltmeter reading is 4.8 V. Explain why the voltmeter reading is less than the e.m.f. of the battery.

---



---



---

[2]

- (c) Calculate the internal resistance of the battery.

---



---



---

[3]

- (d) Calculate the energy transformed per second in the lamp.

---



---



---

[3]

- (e) State two assumptions you made in order to complete these calculations.

(i) \_\_\_\_\_

---



---

[2]

(ii) \_\_\_\_\_

---



---

[2]

2 (a) Define electrical resistance.

[1]

(b) The two graphs below represent current-voltage characteristics for a metal conductor and a thermistor.

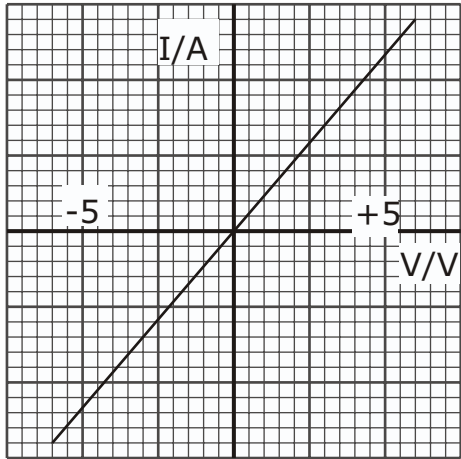

Metallic conductor

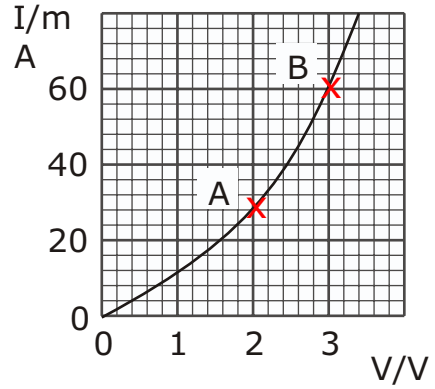

Thermistor

(i) The resistance of the metal conductor is  $833 \Omega$ . Use this value to find appropriate values to label the current axis on the graph.

[3]

(ii) Calculate the change in resistance of the thermistor between the points A and B marked on the graph.

[3]

(iii) What do the graphs tell you about the difference in behaviour between the metal and the thermistor?

[2]



AS Circuits

**3** A copper wire is 2.0 m long and has a cross-sectional area of 1.0 mm<sup>2</sup>. It has a p.d. of 0.12 V across it when the current in it is 3.5 A.

(i) Draw a circuit diagram to show how you would check these voltage and current values. [3]

(ii) Calculate the rate at which the power supply does work on the wire i.e. the power dissipated in the wire.

---

---

---

[2]

(iii) Copper has about  $1.7 \times 10^{29}$  electrons per cubic metre. Calculate the drift speed of the charge carriers in the wire.

---

---

---

---

[3]

(iv) The power from the supply connected to the wire is equal to the total force  $F_t$  on the electrons multiplied by the drift speed at which the electrons travel. Calculate  $F_t$ .

---

---

---

---

[2]

- 4 The diagram below shows a circuit for measuring resistance (i.e. an ohmmeter).  
 Before any readings are taken, the two probes are connected together and the variable resistor adjusted so that the meter reads full scale deflection.

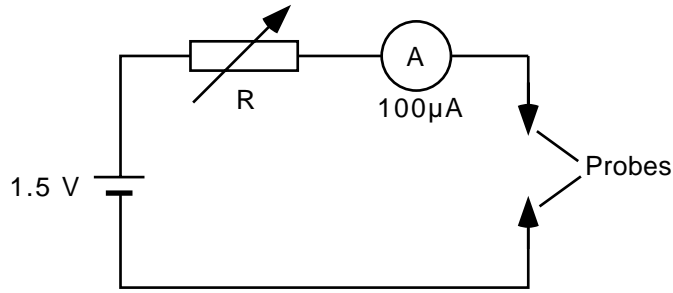

- (a) Calculate the resistance of R for full-scale deflection.

---



---



---

[2]

- (b) With R fixed at this value, what additional resistance connected between the probes would give a meter reading of  
 (i) a half of the full scale deflection,

---



---



---

[2]

- (ii) a quarter of the full scale deflection from the 0 μA end of the scale?

---



---



---

[2]

- (c) Use your calculated values to mark the scale below so that it would show directly the resistance of any component connected between the probe terminals. Mark the full range of the scale below. [3]

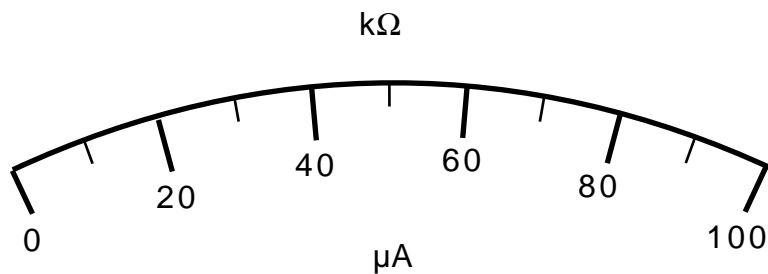

- 5** A semiconducting strip, 6 mm wide and 0.5 mm thick, carries a current of 8mA. The carrier density is  $7 \times 10^{23} \text{ m}^{-3}$ . Calculate the carrier drift speed.

---

---

---

[3]

An approximate value for the drift speed in a copper wire of the same dimensions and carrying the same current would be about  $10^{-7} \text{ ms}^{-1}$ . Compare this figure with your calculated result and account for any difference in terms of the equation  $I = nAqv$ .

---

---

---

[3]

Explain why the resistance of a semiconducting strip decreases when its temperature rises.

---

---

---

---

[2]

- 6** A torch has three identical cells, each of e.m.f. 1.5 V, and a lamp that is labelled 3.5 V, 0.3 A.  
(i) Draw a circuit diagram for the torch. [2]

- (ii) Assume that the lamp is lit to normal brightness and that the connections have negligible resistance. Mark on your diagram the voltage across each circuit component and the current flowing in the lamp. [3]

- (iii) Calculate the internal resistance of one of these cells.

---

---

---

---

[3]

AS Circuits

7 A cell of negligible internal resistance is connected in series with a microammeter of negligible resistance and two resistors of  $10\text{ k}\Omega$  and  $15\text{ k}\Omega$ . The current is  $200\text{ }\mu\text{A}$ .

(a) (i) Draw a circuit diagram of the arrangement. [1]

(ii) Calculate the e.m.f. of the cell.

---

---

---

[2]

(b) (i) When a voltmeter is connected in parallel with the  $15\text{ k}\Omega$  resistor, the current in the microammeter increases to  $250\text{ }\mu\text{A}$ . Sketch a diagram of the modified circuit. [1]

(ii) Calculate the resistance of the voltmeter.

---

---

---

[3]

- 8 You are given a piece of resistance wire. It is between two and three metres long and has a resistance of about  $15 \Omega$ . You are asked to measure the resistivity of the metal alloy it is made from.

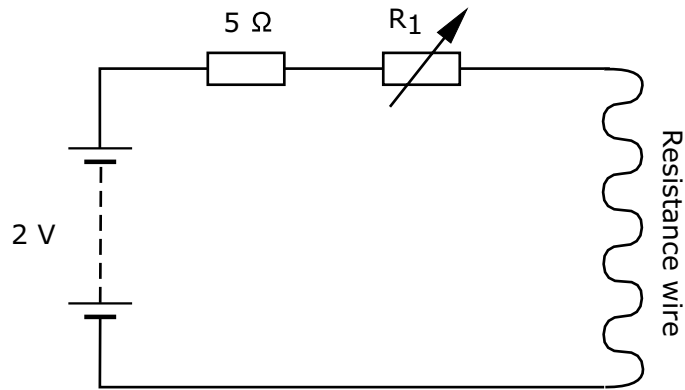

Make the necessary additions to the following circuit to enable it to be used for the experiment. [2]  
Describe briefly how you would use the circuit above to measure the resistance of the wire.

---

---

---

---

---

---

---

---

---

---

---

---

Once the resistance of the wire is known, two more quantities must be measured before its resistivity can be calculated. What are they?

---

---

---

---

---

---

---

Is there any advantage in finding the resistance of the wire from a graph compared with calculating an average value from the measurements? Explain your answer.

---

---

---

---

---

---

---

- 9 The circuit diagram shows a 12 V power supply connected across a potential divider R by the sliding contact P. The potential divider is linked to a resistance wire XY through an ammeter. A voltmeter is connected across the wire XY.

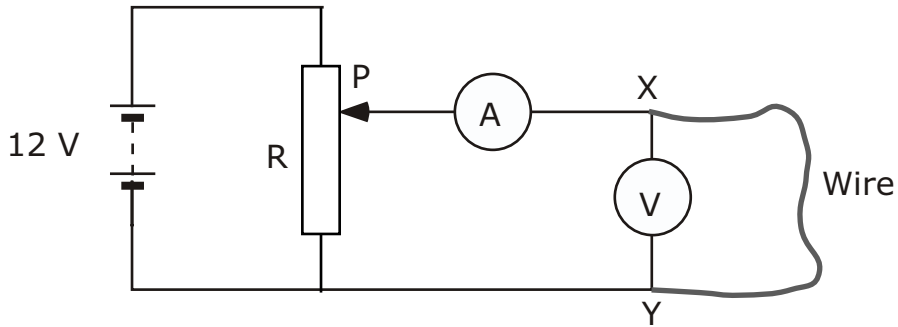

- (a) Explain, with reference to this circuit, the term potential divider.

---



---



---



---

[2]

- (b) The circuit has been set up to measure the resistance of the wire XY. A set of voltage and current measurements is recorded and used to draw the following graph.

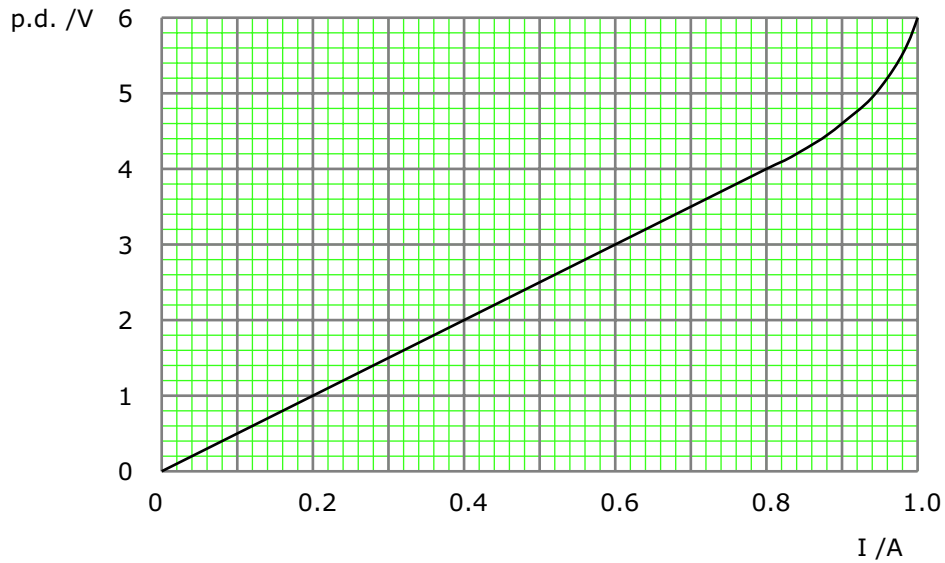

- (i) Explain why the curve deviates from a straight line at higher current values.

---



---



---



---

[2]

9 cont.

(ii) Calculate the resistance of the wire for low current values.

---

---

---

---

[2]

(c) To determine the resistivity of the material of the wire, two more quantities would have to be measured. What are they?

Explain which of these two measurements you would expect to have the greater influence on the error in a calculated value for the resistivity? How would you minimise this error?

---

---

---

---

[3]

**10** (i) Define the term *resistivity*.

---

---

[2]

(ii) The resistivity of copper is  $1.7 \times 10^{-8} \Omega\text{m}$ . A copper wire is 0.6 m long and has a cross-sectional area of  $1 \text{ mm}^2$ . Calculate its resistance.

---

---

---

---

[3]

Two such wires are used to connect a lamp to a power supply of negligible internal resistance. The potential difference across the lamp is 12 V and its power is 36 W.

(iii) Calculate the potential difference across each wire.

---

---

---

---

[3]

(iv) Draw a circuit diagram of the above arrangement. Label the potential differences across the wires, lamp and power supply. [3]

11 (a) Define the term resistivity.

---



---



---



---

A student is asked to measure the resistivity of the alloy nichrome given a nichrome wire known to have a resistance of about two or three ohms. The wire is mounted between two copper clamps, X and Y, near the ends of the wire. The power supply is a variable power supply of output 0-5 V. The series resistor is 80 Ω.

(b) Complete the following circuit diagram.

[2]

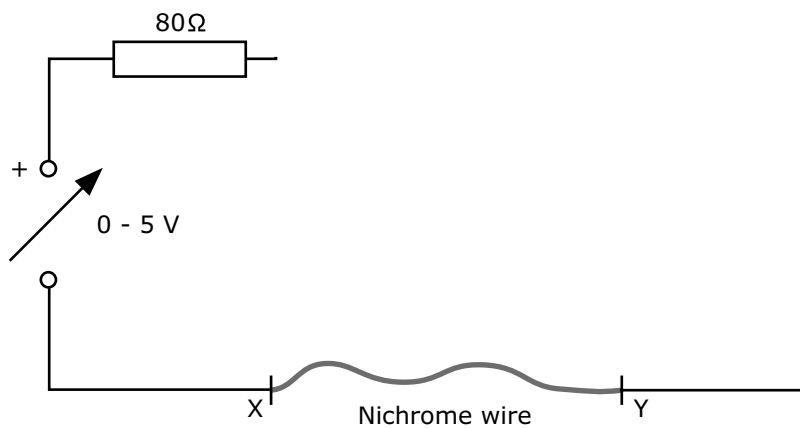

(ii) The 80 Ω series resistor ensures that the current is kept small. Explain why this is important.

---



---



---



---



11 cont.

- (c) A number of measurements were made of the voltage across the wire for different values of the current flowing in it. The following graph was drawn.

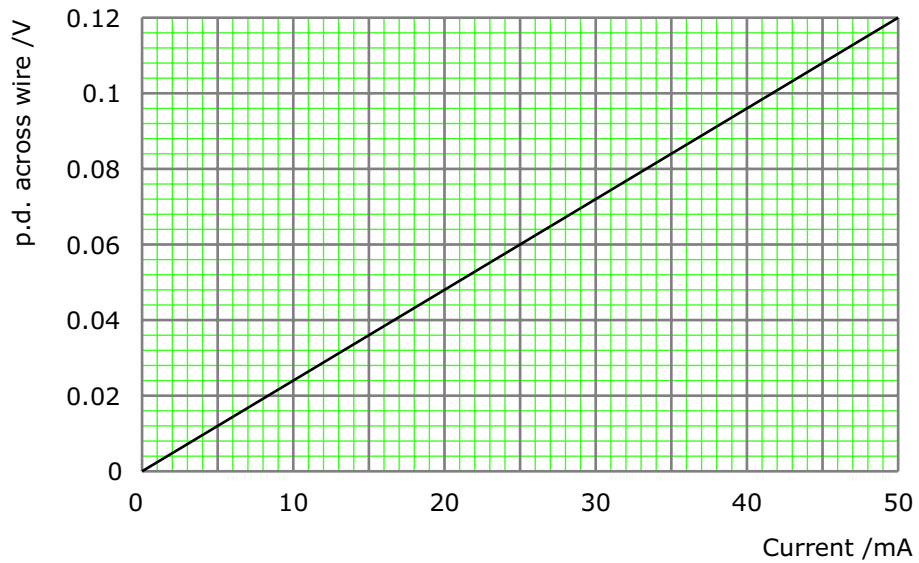

- (i) Calculate the resistance of the nichrome wire.

---



---



---



---

[3]

- (ii) The length of wire between the clamps is 51 cm. The diameter of the nichrome wire is 0.59 mm. Calculate the resistivity of the nichrome.

---



---



---



---

[3]



12 cont.

- (b) (i) A battery has an e.m.f. of 12.0 V and an internal resistance of 3.0  $\Omega$ . Calculate the p.d. across the battery when it is delivering a current of 3.0 A.

---



---

[2]

- (ii) The same battery is now connected to a filament lamp. The graph shows how the p.d. across the lamp would depend on the current through it.

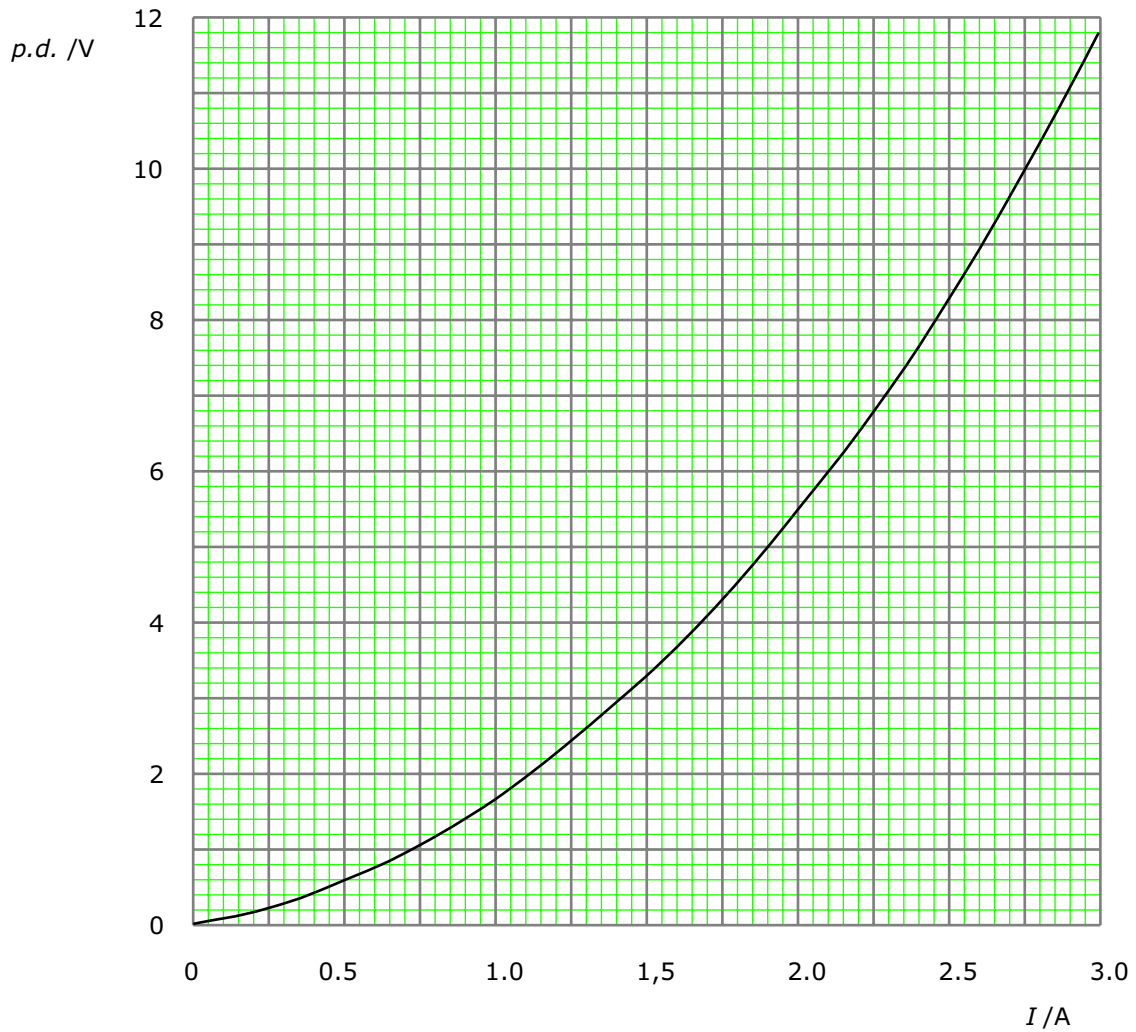

- (ii) Use your answer to part (i) to help you draw, on the same axes, a line showing how the p.d. across the battery would depend on the current through it. [1]

What current will the battery drive through the lamp?

---

[1]

**13** The circuit shows a battery of negligible internal resistance connected to three resistors.

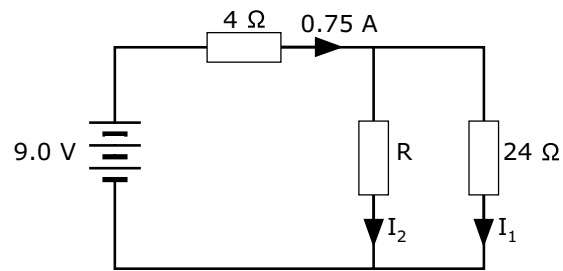

(i) Calculate the p.d. across the 4 Ω resistor.

---



---



---

[2]

(ii) Calculate current  $I_1$ .

---



---



---



---

[3]

(iii) Calculate resistance  $R$ .

---



---



---



---

[2]

- 14 (a) The circuit shown is used to produce a current-voltage graph for a 12 V, 24 W lamp.

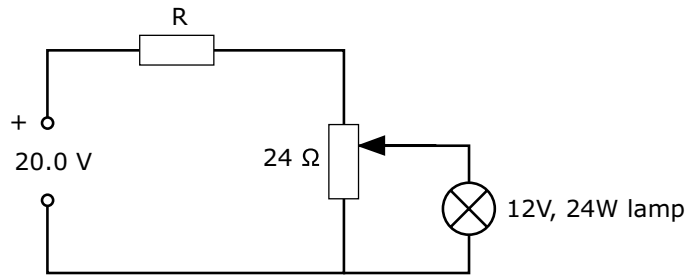

- (i) Show on the diagram the correct positions for a voltmeter and an ammeter. [2]  
 (ii) Calculate the resistance of the lamp in normal operation.

---



---



---

[3]

- (iii) Calculate the value for R that would enable the voltage across the lamp to be varied between 0 V and 12 V.

---



---



---



---



---



---



---



---

[6]

- (b) State whether the following statements are true or false. Give reasons in each case.

- (i) When a battery is connected across a thick wire in series with a thin wire of the same material, electrons move faster through the thick wire.

---



---



---

[2]

- (ii) When a battery is connected across a high resistance in parallel with a low resistance, more power is dissipated in the low resistance.

---



---



---

[2]

- 15** (a) Sketch and label two graphs to show how the current varies with potential difference for  
 (i) a metal wire, and  
 (ii) a semiconductor diode,  
 both at constant temperature. [2]

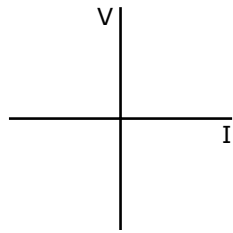

Metal wire

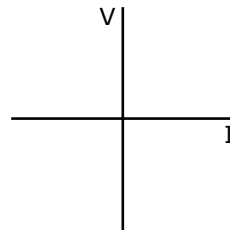

Semiconductor diode

A semiconductor diode carries a current of 20 mA in normal operation. The potential difference across it should be 1.9 V. Complete the diagram below to show how, with the addition of a single component, the semiconducting diode may be powered from a 5 V supply. [1]

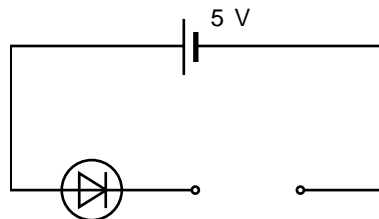

- (b) Calculate the value of the additional component required.

---



---



---

[3]

- 16** (a) The terminal potential difference of a cell is always less than the e.m.f. when there are "lost volts" across the internal resistance.

(i) State a typical value for the e.m.f. of a single dry cell. \_\_\_\_\_ [1]

(ii) State a typical value for the terminal potential difference for a dry cell when it is supplying a normal load.

---

[1]

(iii) Sketch a diagram to show how many such cells you would use, and how you would connect them, to provide a power supply for a 9 V radio. [3]

(b) Some dry cells can cause serious burns if short-circuited by a bunch of keys while being carried in a pocket. Explain why this problem occurs only with cells like nickel cadmium cells, which have a very low internal resistance.

---



---

[3]

**17** The power supplies in the two circuits shown below are identical.

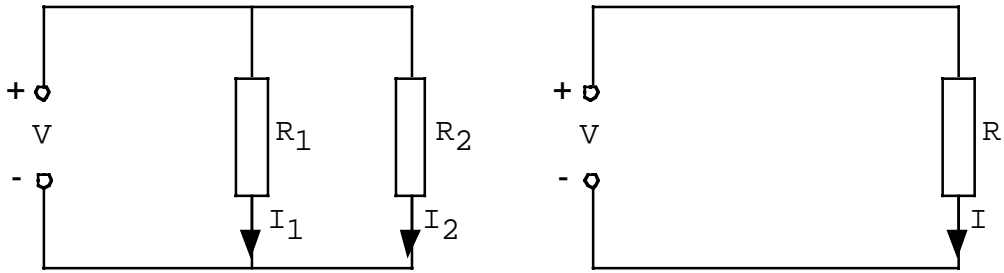

(i) Write down the relationship between  $I_1$ ,  $I_2$  and  $I$  that must hold if the combined resistance of the parallel pair,  $R_1$  and  $R_2$ , is to equal  $R_T$ .

---



---



---

[1]

(ii) Hence derive the formula for the equivalent resistance of two resistors connected in parallel.

---



---



---

[3]

(iii) Use your formula to show that the resistance between the terminals of a low-resistance component is hardly changed when a high-resistance voltmeter is connected in parallel with it.

---



---



---

[2]

18 The graph shows how the resistance  $R$  of a thermistor depends on temperature.

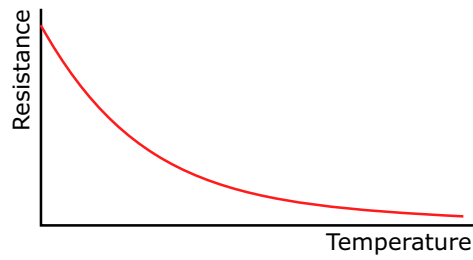

(a) In terms of the behaviour of the material of the thermistor, explain qualitatively the variation shown on the graph.

---



---



---



---

[2]

A student connects the thermistor in series with a  $330\ \Omega$  resistor and applies a potential difference of  $2.0\ \text{V}$ . A high resistance voltmeter connected in parallel with the resistor reads  $0.80\ \text{V}$ .

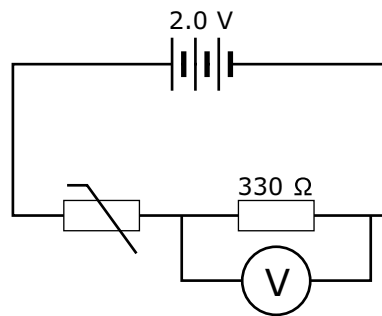

(b) (i) Calculate the resistance of the thermistor.

---



---



---



---

[3]

(ii) The student now increases the applied p.d. from  $2.0\ \text{V}$  to  $20\ \text{V}$ . She expects the voltmeter reading to increase from  $0.80\ \text{V}$  to  $8.0\ \text{V}$  but is surprised to find that it is greater. Explain this.

---



---



---



---

[3]



19 The resistors  $R_1$  and  $R_2$  in circuit (fig. 1) are equivalent to a single resistor  $R$  in circuit (fig. 2).

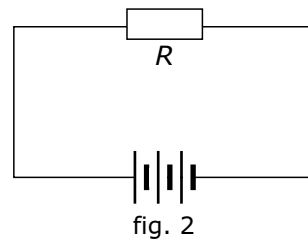
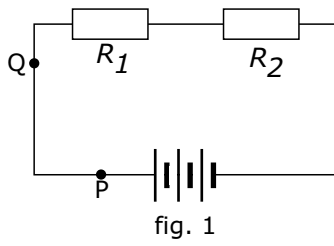

(a) Prove that  $R = R_1 + R_2$ .

---



---



---



---

[3]

(b) (i) In a real circuit it is usually assumed that there is no potential difference between two points, such as P and Q in figure 1, which are on the same connecting lead. Explain why this is usually a good approximation.

---



---



---

[2]

(ii) In what circumstances might the approximation break down?

---

[1]

(c) A laboratory lead consists of 16 strands of fine copper wire twisted together. Each strand is 30 cm long with a diameter of 0.15 mm. Calculate the potential difference across the lead when it is carrying a current of 2.0 A.

(The resistivity of copper =  $1.7 \times 10^{-8} \Omega\text{m}$ .)

---



---



---



---

[4]

- 20** The diagram shows the circuit of a fluorescent light fitting. It consists of a tube, a starter and a ballast resistance of  $300\ \Omega$ .

The fluorescent tube is filled with gas. It contains two filaments at A and B of resistance  $50\ \Omega$  that heat the gas.

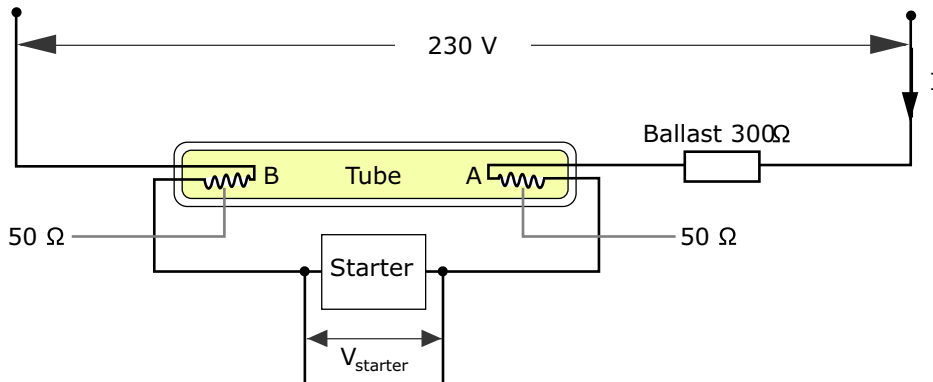

When the light is first turned on, the tube does not conduct but the starter does, drawing a current of  $0.50\ \text{A}$  from the  $230\ \text{V}$  supply.

- (a) (i) Calculate the voltages across the ballast resistor and each filament when the current flows

---



---



---

[4]

- (ii) Mark these voltages on the diagram, and hence calculate the voltage across the starter when the starting current is flowing. Mark your answer on the diagram.

[2]

- (b) The starting current heats the filaments and the gas in the tube but the voltage across the tube is not large enough to make it conduct. However, after a few seconds the starter stops conducting. The voltage across the tube rises and the gas conducts. A current now flows from A to B and the tube lights up.

- (i) What fundamental change is necessary for a gas, which was an insulator, to be able to conduct?

---



---

[1]

- (ii) Now that the tube is conducting, the voltage across AB is  $110\ \text{V}$ . Calculate the power dissipated in the whole circuit.

---



---

[3]

- (iii) In a faulty fluorescent lamp the filaments at both ends of the tube glow steadily but the tube does not light up. Identify, with a reason, the faulty component.

---



---

[1]

## Current characteristics 1

Name & Set

In an experiment with a filament lamp, the following readings of p.d. and current were obtained.

p.d./ V	0	1.0	2.0	3.0	4.0	5.0	6.0
Current/ A	0	0.1	0.19	0.27	0.34	0.40	0.45

(a) Draw a diagram of the circuit you would use in order to obtain these readings.

(b) Plot a graph of p.d. (x-axis) against current (y-axis)

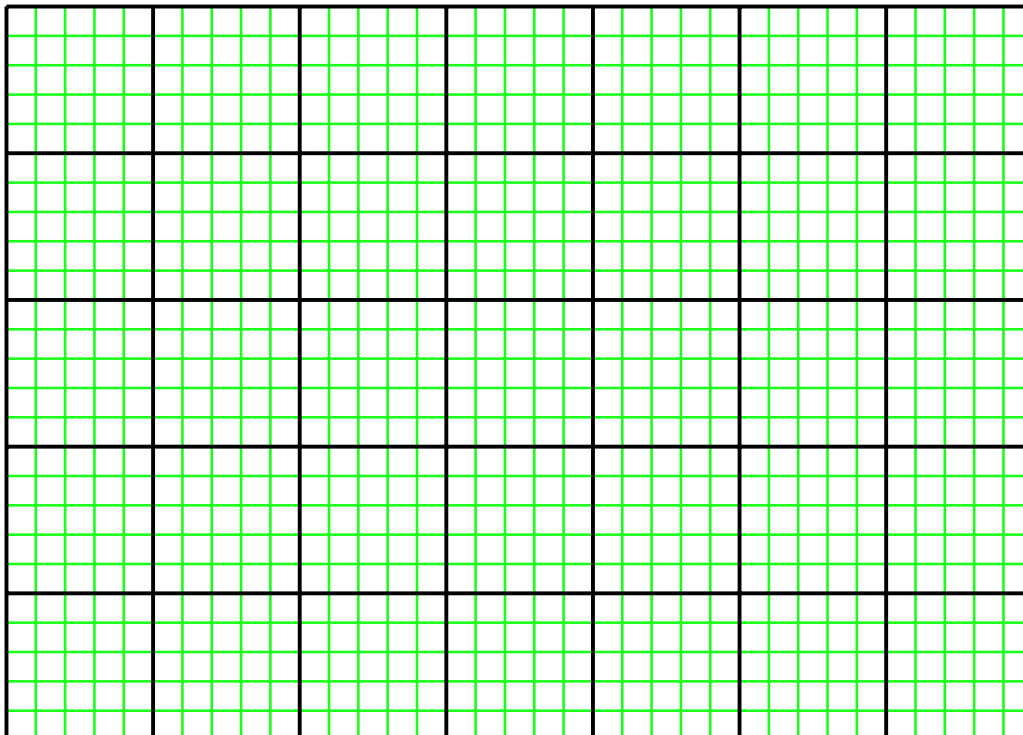

(c) For each pair of readings calculate the resistance of the lamp.

p.d. / V	0	1.0	2.0	3.0	4.0	5.0	6.0
Current / A	0	0.1	0.19	0.27	0.34	0.40	0.45
Resistance / Ohms							

(d) Plot a graph of resistance (y-axis) against current (x- axis.)

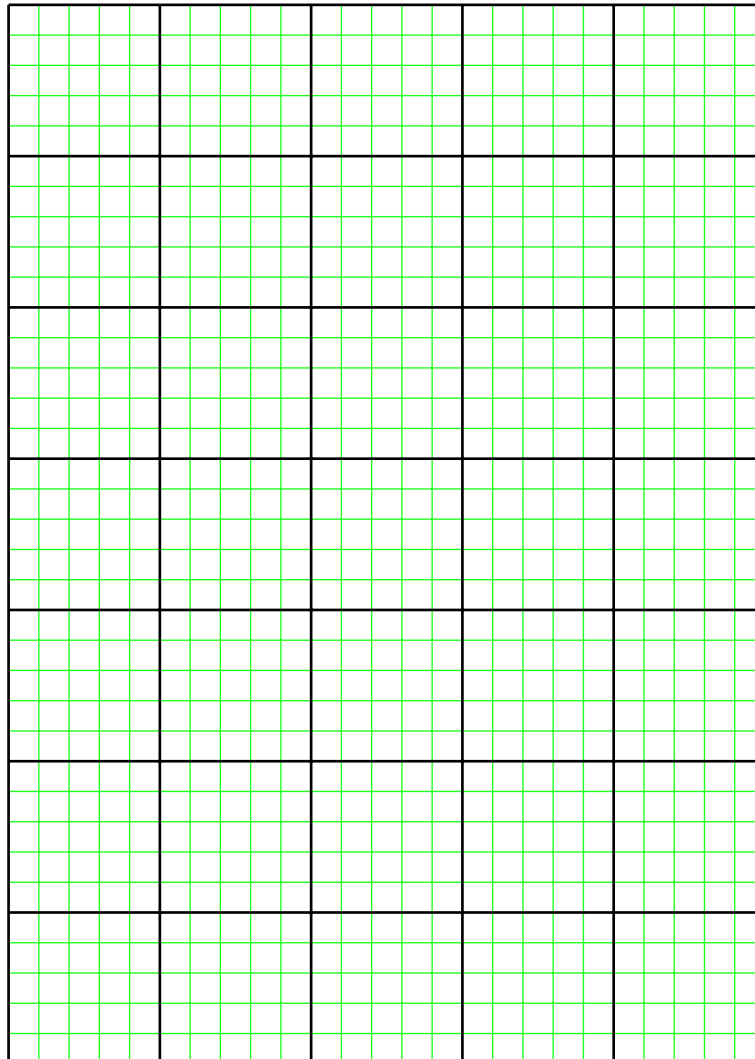

(e) What conclusion can you draw from the graph about the effect of current on the resistance of the filament of the lamp?

[1]

## Current characteristics 2

Name & Set

1 In a physics book a student reads that the resistance of a piece of wire depends upon

- its cross-sectional area
- its length
- the material of which it is made

The student decides to examine how the cross-sectional area of a piece of wire affects its resistance. He selects some pieces of resistance wire, each 1 m long.

(a) (i) Why should all the pieces of wire be made of the same material?

---

---

[2]

(ii) Why should they all be the same length?

---

---

[2]

(b) (i) Using the standard symbols for electrical components draw a circuit diagram for the circuit that you would use in this experiment in the space below.

[4]

(i) Write down in words in the space below the equation that links *RESISTANCE*, *CURRENT* and *VOLTAGE*.

[2]

(ii) What measurements would you make to determine the resistance of the wire?

---

---

[2]

(c) Using each of the wires in turn the voltage was varied, and both the voltage and the current were measured. A graph of these results was plotted in each case.

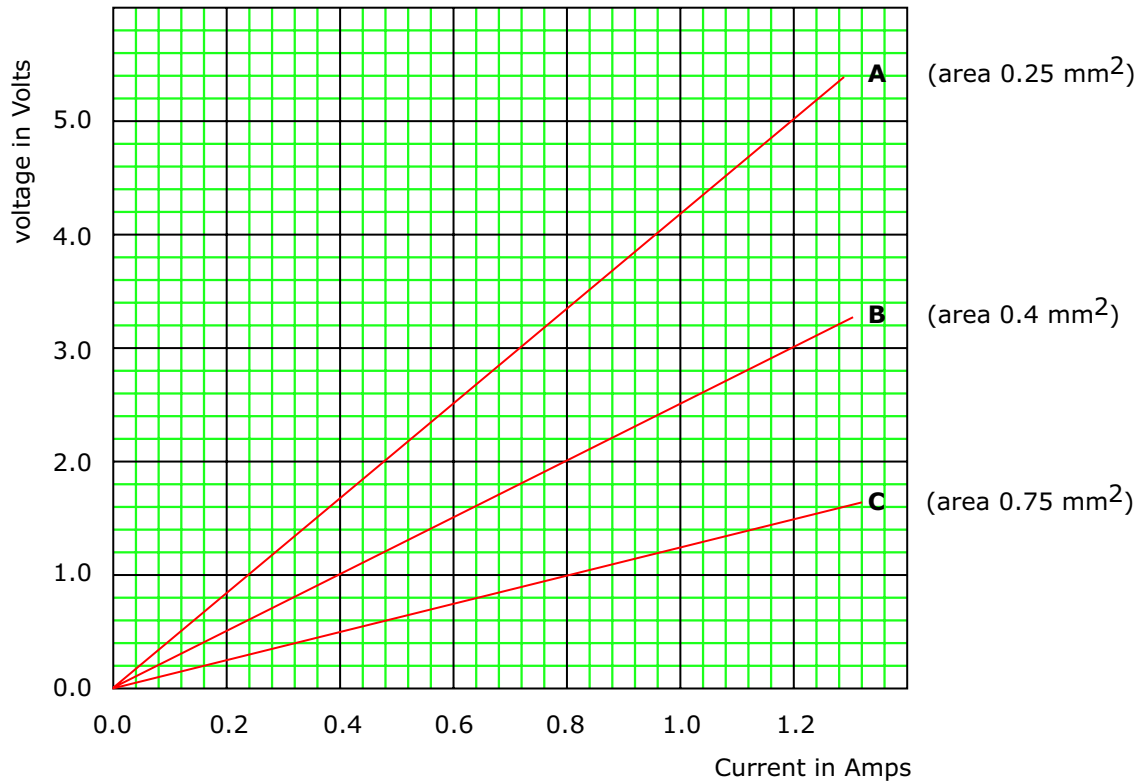

(i) For each wire, find the resistance, showing how you do your calculation.

Wire A \_\_\_\_\_  
 \_\_\_\_\_ [2]

Wire B \_\_\_\_\_  
 \_\_\_\_\_ [2]

Wire C \_\_\_\_\_  
 \_\_\_\_\_ [2]

(ii) Use the graph to explain what the effect of changing the voltage will be on the current through the wire \_\_\_\_\_  
 \_\_\_\_\_ [2]

resistance of the wire \_\_\_\_\_  
 \_\_\_\_\_ [2]

(iii) The cross-sectional areas of the wires are shown on the graph. What would you say happens to the resistance of the wires as the cross-sectional area increases?  
 \_\_\_\_\_  
 \_\_\_\_\_ [2]